



IOT BASED ACCIDENT MONITORING AND AMBULANCE DISPATCH SYSTEM FOR REAL - TIME RESCUE

M. Bhuvanewari*, K. Kamelesh, R. Jagadeeson**, V. Murugan** & R. Poovarasana****

* Assistant Professor, Department of Electrical and Electronics Engineering, Dhanalakshmi Srinivasan Engineering College (Autonomous), Perambalur, Tamil Nadu, India

** UG Student, Department of Electrical and Electronics Engineering, Dhanalakshmi Srinivasan Engineering College (Autonomous), Perambalur, Tamil Nadu, India

Cite This Article: M. Bhuvanewari, K. Kamelesh, R. Jagadeeson, V. Murugan & R. Poovarasana, "IoT Based Accident Monitoring and Ambulance Dispatch System for Real - Time Rescue", International Journal of Advanced Trends in Engineering and Technology, Volume 11, Issue 1, January - June, Page Number 75-80, 2026.

Copy Right: © DV Publication, 2026 (All Rights Reserved). This is an Open Access Article distributed under the Creative Commons Attribution License, which permits unrestricted use, distribution, and reproduction in any medium provided the original work is properly cited.

Type of Review: Peer Reviewed as per |C|O|P|E| Guidance.

Disclaimer: The scholarly papers reviewed and published by DV Publication, India, reflect the views and opinions of their respective authors and do not necessarily represent the views or opinions of DV Publication. The publisher disclaims any responsibility for any harm, loss, or damage resulting from the use of the published content by any party.

DOI: <https://doi.org/10.5281/zenodo.19740655>

Abstract:

Road traffic accidents remain a leading cause of fatalities and critical injuries, particularly when emergency medical services are delayed. This work proposes an Internet of Things (IoT) enabled accident detection and ambulance dispatch system aimed at enabling rapid rescue operations. The system employs multiple sensors, including accelerometers, vibration detectors, tilt sensors, and impact sensors, to identify accident events in vehicles. Upon detecting a crash, the system immediately retrieves the geographic location using GPS and transmits alert notifications through GSM or internet-based communication to emergency responders, hospitals, and registered contacts. The embedded controller analyzes sensor inputs to distinguish genuine accidents from normal disturbances, thereby minimizing false alerts. A cloud-based platform stores critical information such as vehicle identity, accident time, and location details, supporting faster decision-making. Additionally, an ambulance dispatch module identifies and assigns the nearest available ambulance to the accident site. Experimental validation and simulations demonstrate that the system provides accurate detection, quick alert transmission, and reliable location tracking, thereby improving emergency response efficiency.

Key Words: IoT, Accident Detection, Emergency Response, GPS Tracking, Ambulance Dispatch, Smart Healthcare, Vehicle Monitoring, Crash Detection, Rescue Automation

Introduction:

The rapid increase in road accidents has highlighted the urgent need for intelligent emergency response mechanisms capable of delivering timely assistance. In many situations, fatalities occur not only due to the accident itself but also because emergency services are not informed promptly about the incident location or severity. Conventional accident reporting methods rely on witnesses or manual communication, which often results in critical delays. To address this limitation, an automated accident detection and notification system is essential. The proposed IoT based system integrates sensing devices, positioning modules, wireless communication, and cloud computing to enable immediate response. Once an accident occurs, the system automatically transmits location details and emergency alerts to relevant stakeholders such as hospitals, ambulance services, and family members. This approach ensures faster coordination and reduces response time, ultimately enhancing survival chances.

System Architecture:

The architecture of the proposed system consists of multiple interconnected modules designed for rapid detection and emergency response

- Sensor Layer - Detects motion, vibration, tilt, and impact conditions.
- Processing Unit - An embedded controller analyzes sensor data and identifies accident events.
- Positioning Module - GPS provides accurate location coordinates.
- Communication Module - GSM/Wi-Fi/LTE transmits alerts to emergency services.
- Cloud Platform - Stores and processes accident data, enabling monitoring.
- Dispatch System - Assigns the nearest ambulance for rescue.
- Response Unit - Ambulance reaches the accident location for immediate assistance.

This layered approach ensures efficient data flow and rapid decision-making.

System Design and Methodology:

The proposed design integrates hardware sensing, embedded control, communication networks, and cloud-based monitoring.

Block Diagram:

In traditional accident response systems, emergency reporting depends heavily on human intervention. Victims or bystanders must manually inform authorities, which can cause significant delays, especially if the victim is unconscious. Although modern vehicles include safety features such as airbags, they do not automatically notify emergency services. Surveillance systems may capture accidents, but they require constant monitoring and do not guarantee immediate response. Once the information reaches emergency centers, manual verification and ambulance dispatch further increase delays. Hospitals also remain unprepared due to lack of prior information. The proposed system eliminates these inefficiencies by automating detection,

communication, and dispatch processes.

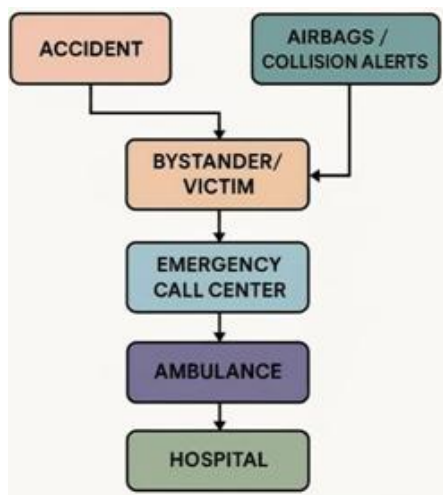

Hardware Integration:

The system is implemented using modular hardware components to ensure flexibility and cost-effectiveness. Key components include:

- Accelerometer and vibration sensors
- Microcontroller (Arduino / ESP32 / Raspberry Pi Pico)
- GPS module
- GSM/Wi-Fi communication module
- Buzzer for alerts
- Emergency push button and reset switch
- LCD display or mobile interface
- Cloud monitoring system
- Ambulance tracking interface

Software Methodology:

The software is designed for continuous monitoring and fast decision-making. Sensor data is collected and filtered to remove noise. The controller compares real-time values with predefined thresholds to detect abnormal conditions. When an accident is confirmed, the system retrieves GPS coordinates and sends alert messages to cloud servers and emergency contacts. A monitoring dashboard displays accident details such as vehicle ID, location, and time. The software can be developed using Embedded C, Python, or IoT platforms.

Simulation and Prototyping:

The system is validated through simulation and prototype testing. Various conditions such as minor disturbances, severe impacts, and manual triggers are tested to evaluate performance. The results indicate that:

- Sensor data is accurately processed in real time
- Accident conditions are correctly identified
- GPS location is reliably captured
- Alerts are transmitted without delay

Software Tools:

The design, simulation, implementation, and validation of the proposed system can be carried out using the following tools:

- Arduino IDE - for microcontroller programming and sensor interfacing.
- Proteus - for circuit simulation and controller validation.
- MATLAB/Simulink - for sensor data modeling and threshold analysis.
- Thing Speak / Blynk / Firebase - for IoT cloud monitoring and alert storage.
- Google Maps API - for location display and route assistance.
- Embedded C / Python - for control and dashboard software development.

Working Principle:

The system operates in sequential stages:

- Sensors continuously monitor vehicle conditions
- The controller evaluates sensor readings
- Abnormal patterns trigger accident detection
- GPS retrieves location coordinates
- Communication module sends alerts
- Cloud platform processes and displays data
- Ambulance is dispatched to the accident site

Parameter Aggregation:

A. Sensor Parameters:

- Acceleration

- Vibration intensity
- Tilt angle
- Sudden deceleration
- Manual emergency input

B. Communication Parameters:

- GPS coordinates
- Transmission delay
- Signal strength
- Delivery status

C. Response Parameters:

- Detection time
- Alert delay
- Dispatch time
- Arrival estimation

D. Sensor Parameters:

The main sensing parameters include:

- Acceleration level.
- Vibration intensity.
- Vehicle tilt angle.
- Sudden speed drop.
- Manual emergency switch status.

These values are used together to improve accident detection accuracy and reduce false triggering.

E. Communication Parameters:

The communication-related parameters include:

- GPS latitude and longitude.
- Alert transmission time.
- Network signal strength.
- Message delivery status.
- Ambulance acknowledgement status.

F. Response Parameters:

The rescue performance can be evaluated using:

- Accident detection time.
- Alert generation delay.
- Ambulance dispatch time.
- Estimated arrival time.
- System reliability under different network conditions.

Spatial and Temporal Aggregation:

Spatial aggregation combines data from sensors, GPS, cloud servers, and ambulance systems into a unified framework. Temporal aggregation analyzes sensor data over time to differentiate actual accidents from temporary disturbances. This improves detection accuracy and reduces false alarms.

Circuit Diagram:

The proposed circuit consists of the following major sections:

- Sensor input section for accident detection.
- Microcontroller processing unit.
- GPS tracking section.
- GSM/Wi-Fi communication section.
- Local alarm and display section.
- Power supply and voltage regulation section.

All modules are integrated so that, after accident detection, the controller can immediately activate alert generation and communication.

The proposed system operates on an Arduino based health and accident monitoring circuit that integrates multiple biomedical and motion-sensing modules. A regulated power supply consisting of a bridge rectifier and 7812/7805 voltage regulators provides stable 12V and 5V outputs to all components. The heart rate and SpO₂ sensor measures the pulse and blood oxygen level, and its output is filtered through an inductor-capacitor network before reaching the Arduino's analog input. A temperature sensor provides continuous body temperature data, while a gyro sensor detects sudden tilts, impacts, or abnormal body movements that may indicate an accident or fall. Simultaneously, a GPS module supplies the real-time latitude and longitude of the user. The Arduino processes all sensor inputs, displays vital parameters on the LCD, and triggers a buzzer and emergency alert whenever abnormal health conditions or accident events are detected. The IoT/GSM module then transmits the alert along with GPS location to a remote monitoring server or guardian. Thus, the entire circuit functions as a compact IoT enabled health and accident detection system capable of real-time monitoring and rapid emergency response.

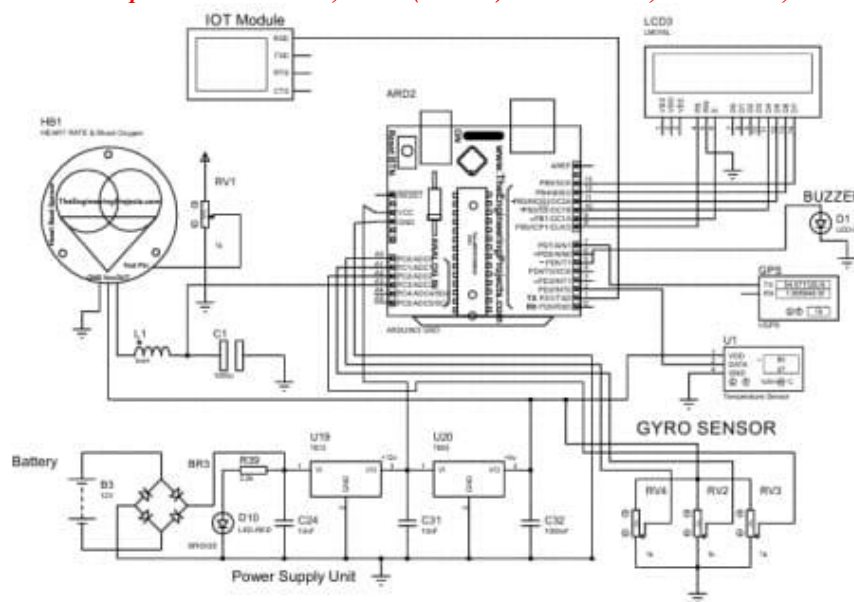

Power Supply and Grounding:

The power supply architecture is designed to ensure stable operation of the sensing, control, and communication modules. A regulated DC supply is used to power the microcontroller, sensors, GPS, and GSM modules. Proper voltage regulation is required because communication modules may draw sudden peak current during data transmission.

Grounding should be arranged carefully to reduce electrical noise and improve sensor accuracy. Power ground and signal ground must be managed properly in the PCB or prototype layout. Isolation and filtering techniques can be added if the system is directly integrated into an automobile electrical environment.

Simulation Diagram:

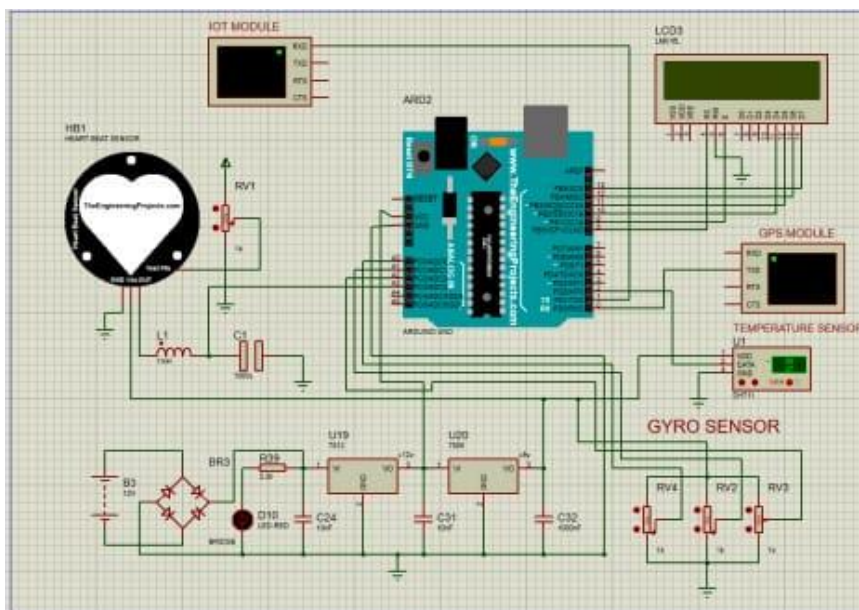

The simulation diagram illustrates the complete architecture of an IoT-based Health and Accident Monitoring System developed using an Arduino Uno microcontroller. The circuit integrates multiple sensing modules to collect real-time physiological and environmental data. A heartbeat sensor monitors the pulse rate, while a DHT11 temperature sensor measures body temperature or ambient conditions. A three-axis gyro sensor is included to detect sudden tilt, vibration, or impact, which is essential for identifying accidents. These sensors are connected to the analog and digital input pins of the Arduino, where the signals are processed and analyzed. The system also incorporates a GPS module that provides continuous tracking of the user's geographical coordinates, enabling accurate location reporting in case of emergencies. Additionally, an IoT communication module is used to transmit the processed data, such as abnormal heart rate, high temperature, or crash detection, to a cloud platform or a registered mobile number for remote monitoring. A regulated power supply section, equipped with a bridge rectifier, smoothing capacitors, and voltage regulators (7812 and 7805), ensures a stable and noise-free DC supply for the entire circuit. The real-time readings from all sensors are simultaneously displayed on a 16x2 LCD, allowing local monitoring during operation. Overall, the simulation demonstrates how different biomedical, motion, and communication modules are integrated into a unified embedded system capable of detecting critical health issues, identifying accidents, locating the user, and sending immediate alerts through IoT technology. This makes the design highly suitable for applications such as vehicle safety, patient care, elderly monitoring, and smart emergency response systems.

Simulation Result 1:

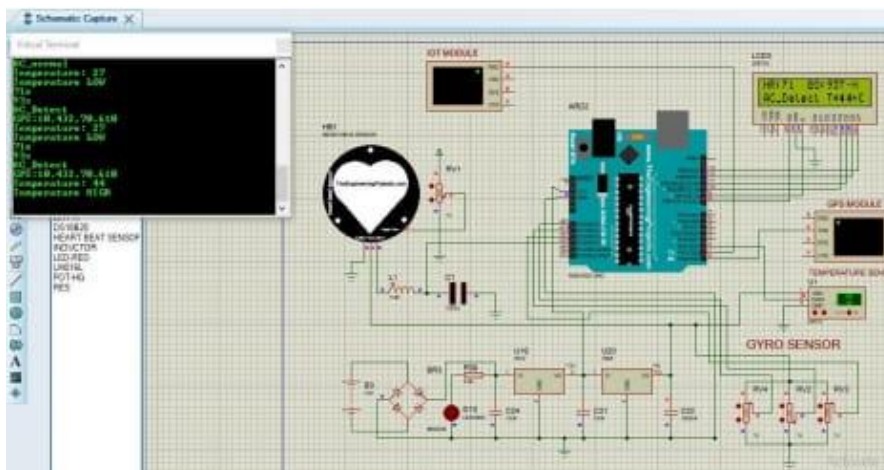

The simulation results show that the system successfully reads and processes data from all connected sensors in real time. The virtual terminal displays continuous updates of the user's temperature, heart rate, accident status, and GPS location. In normal conditions, the system shows messages like AC normal along with a stable temperature reading (e.g., 27°C). When the body temperature decreases or increases, the system clearly identifies and displays status messages such as Temperature LOW or Temperature HIGH. During the simulated accident condition, the system detects abnormal movement from the gyro sensor and immediately displays AC Detect on both the virtual terminal and the LCD. At the same time, the GPS module provides coordinates (e.g., 10.432, 70.610), confirming that the system can transmit the location when an accident occurs. The LCD also shows corresponding values such as heart rate (HR), body temperature (T), and accident alert codes. Overall, the simulation confirms that the designed system accurately senses, processes, and displays critical parameters, making it reliable for real-time health and accident monitoring applications.

Simulation Result 2:

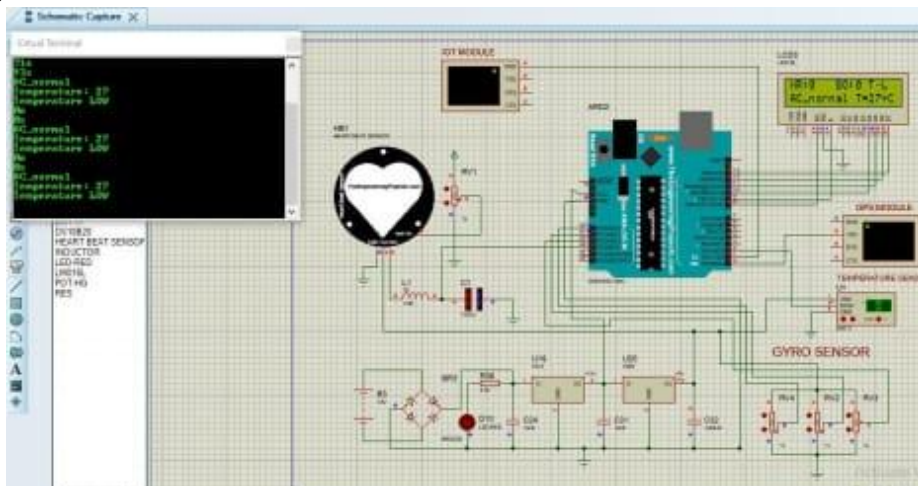

The simulation results confirm that the system is functioning correctly and continuously monitoring the user's vital parameters and accident status. The virtual terminal displays repeated readings of temperature, heart rate, and the accident detection status. In the simulation, the temperature sensor outputs a constant value of 27°C, and the system correctly classifies it as Temperature LOW. At the same time, the accident detection module indicates AC normal, showing that no abnormal movement or impact is detected by the gyro sensor. The LCD display also shows corresponding values such as HR: 0 and BO: 0, as no heartbeat activity is being simulated in this test condition. The message AC normal T=27°C on the LCD confirms that both the temperature reading and accident status are being processed and displayed correctly. Overall, the simulation results demonstrate that sensor data acquisition, processing by the Arduino, and display on the LCD and virtual terminal are all working as expected.

Result and Discussion:

Experimental results confirm that the system can reliably detect accident events and generate alerts within a short time. The integration of multiple sensors enhances detection accuracy, while cloud-based coordination improves emergency response efficiency. The system demonstrates practical applicability in smart transportation and healthcare systems by reducing rescue delays and improving coordination.

Implementation:

The implementation involves integrating hardware modules with embedded software and communication systems. The controller processes sensor inputs, retrieves GPS data, and sends alerts via GSM or IoT platforms. The monitoring dashboard helps emergency personnel identify the nearest ambulance and respond quickly. Testing confirms that the system supports real-time accident detection and rescue coordination.

Conclusion:

This study presents an IoT-based accident detection and ambulance dispatch system designed to improve emergency response efficiency. By automating accident detection and alert generation, the system reduces reliance on manual reporting and

minimizes response delays. The integration of sensors, GPS tracking, communication modules, and cloud platforms enables accurate location sharing and efficient ambulance dispatch. The system offers a scalable and effective solution for enhancing road safety and emergency medical services.

Future Work:

Future enhancements may include:

- AI-based accident severity classification
- Traffic-aware ambulance routing
- Camera-based verification systems
- Integration with law enforcement agencies
- Mobile application support for real-time tracking

Acknowledgment:

The authors express their gratitude to the institution, faculty members, and technical staff for their guidance and support. Appreciation is also extended to friends and family for their encouragement.

References:

1. G. Rathanasabhapathy, M. Dharaneesh, K. S. M. Harivignesh and M. Manikandan, "IoT Based Speed Control Monitoring and Accident Avoidance using AI Traffic Sign Detection," in Proc. 5th Int. Conf. Trends in Material Science and Inventive Materials (ICTMIM), Kanyakumari, India, 2025, pp. 1168-1174.
2. R. Lambor, A. Jadhao, T. Nandane, M. Gaikwad, M. Kanawade and S. More, "Vehicle Accident Alerting and Monitoring with IoT-based Data Analytics," in Proc. 8th Int. Conf. Computing Methodologies and Communication (ICCMC), Erode, India, 2025, pp. 22-26.
3. R. R. F. Lupian, C. G. Arong, W. S. Betinol and D. B. Valdez, "Intelligent Traffic Monitoring and Accident Detection System Using YOLOv11 and Image Processing," in Proc. IEEE Open Conf. Electrical, Electronic and Information Sciences (eStream), Vilnius, Lithuania, 2025, pp. 1-5.
4. M. T, V. P, J. R, S. A, S. H. S and V. R. S, "IoT Based Train Accident Detection System and the Loco-Pilot Health Issue Monitoring Using YOLO Model," in Proc. 3rd Int. Conf. Artificial Intelligence and Machine Learning Applications (AIMLA), Namakkal, India, 2025, pp. 1-5.
5. M. A. Kader, M. Eftekhar Alam, S. Momtaj, S. Necha, M. S. Alam and A. Kadar Muhammad Masum, "IoT Based Vehicle Monitoring with Accident Detection and Rescue System," in Proc. 22nd Int. Conf. Computer and Information Technology (ICCIT), Dhaka, Bangladesh, 2019, pp. 1-
6. V. K, P. Tharun, S. R. S, M. K. R. S, B. S. J and S. R. B, "Integrated Driver Monitoring and Real-Time Accident Detection System using IoT and Computer Vision," in Proc. 5th Int. Conf. Expert Clouds and Applications (ICOECA), Bengaluru, India, 2025, pp. 296-300.
7. S. R, T. D and Y. G, "Real-Time Accident Detection and Response System Using ResNet Algorithm," in Proc. IEEE 16th Int. Conf. Computational Intelligence and Communication Networks (CICN), Indore, India, 2024, pp. 1493-1497.
8. Z. B. Shaik et al., "Autonomous Vehicle Accident Detection with Event Data Recording for Accident Analysis," in Proc. 4th Int. Conf. Artificial Intelligence and Signal Processing (AISP), Vijayawada, India, 2024, pp. 1-5.
9. J. K. Chaithanya, Y. Srilakshmi, M. S. Sphurthi, P. J. Preeth and S. C. Sreedhar, "Real Time Health Monitoring and Accident Detection System," in Proc. 6th Int. Conf. Communication and Electronics Systems (ICES), Coimbatore, India, 2021, pp. 1428-1434.
10. E. M. E. Pardo, J. A. Y. Chero, J. A. Aguirre and A. C. Acosta, "Traffic Accident Monitoring System Using Radio Frequency Identification Tools," in Proc. IEEE 2nd Int. Conf. Advanced Learning Technologies on Education & Research (ICALTER), Lima, Peru, 2022, pp. 1-4.