



AI-DRIVEN SWITCHED CAPACITOR DUAL INPUT CONVERTER FOR SOLAR PV AND BATTERY ENERGY SYSTEMS

K. Anbarasan*, P. Saravanan, R. Rajesh**, S. Santhosh Kumar**
& E. Sabareesh Kumar****

* Professor, Department of Electrical and Electronics Engineering, Dhanalakshmi Srinivasan Engineering College (Autonomous), Perambalur, Tamil Nadu, India

** UG Student, Department of Electrical and Electronics Engineering, Dhanalakshmi Srinivasan Engineering College (Autonomous), Perambalur, Tamil Nadu, India

Cite This Article: K. Anbarasan, P. Saravanan, R. Rajesh, S. Santhosh Kumar & E. Sabareesh Kumar, "AI-Driven Switched Capacitor Dual Input Converter for Solar PV and Battery Energy Systems", *International Journal of Advanced Trends in Engineering and Technology*, Volume 11, Issue 1, January - June, Page Number 87-94, 2026.

Copy Right: © DV Publication, 2026 (All Rights Reserved). This is an Open Access Article distributed under the Creative Commons Attribution License, which permits unrestricted use, distribution, and reproduction in any medium provided the original work is properly cited.

Type of Review: Peer Reviewed as per |C|O|P|E| Guidance.

Disclaimer: The scholarly papers reviewed and published by DV Publication, India, reflect the views and opinions of their respective authors and do not necessarily represent the views or opinions of DV Publication. The publisher disclaims any responsibility for any harm, loss, or damage resulting from the use of the published content by any party.

DOI: <https://doi.org/10.5281/zenodo.19825728>

Abstract:

The rapid growth of distributed renewable energy systems has intensified the demand for compact, efficient, and intelligent power conversion architectures capable of integrating multiple energy sources. Switched-capacitor (SC) converter topologies have emerged as a promising solution due to their high power density, transformer less design, reduced electromagnetic interference, and inherent voltage boosting capability without relying on bulky magnetic components. However, conventional SC converters often face limitations in dynamic response, power-sharing coordination, and efficiency under fluctuating solar irradiance and varying battery states of charge. To address these challenges, this work proposes an AI-driven switched-capacitor dual-input converter (SC-DIC) designed for seamless integration of solar photovoltaic (PV) modules and battery energy storage systems in hybrid renewable power architectures. The proposed SC-DIC topology enables simultaneous processing of power from PV and battery sources, offering flexible operating modes such as PV-only operation, battery-assisted PV operation, battery charging, and standalone battery supply.

Artificial intelligence techniques, including reinforcement learning, fuzzy logic control, and neural network-based predictive optimization, are employed to enhance real-time decision-making, regulate duty cycle modulation, and enable adaptive power flow under dynamic environmental and load conditions. The AI controller predicts optimal switching states, minimizes capacitor voltage ripple, enhances soft-charging behavior, and reduces stress on semiconductor devices. Furthermore, the intelligent supervisory layer ensures optimal maximum power point tracking (MPPT), efficient battery charge-discharge management, and improved transient performance under intermittent solar input. Simulation and analytical results demonstrate that the AI-driven SC-DIC achieves higher conversion efficiency, faster dynamic response, and improved stability compared with conventional dual-input converters and fixed-rule SC control methods. The system reduces switching losses, enhances voltage gain, and ensures balanced power sharing between PV and battery sources. With its compact design, intelligent control, and capability to integrate dual renewable sources, the proposed converter presents a scalable and robust solution for next-generation DC microgrids, solar home systems, EV charging stations, and distributed energy storage applications.

Key Words: AI-Driven Control, Switched Capacitor Converter, Dual-Input DC-DC Converter, Solar Photovoltaic (PV) Systems, Battery Energy Storage Systems (BESS), Hybrid Energy Systems, Power Management, Intelligent Energy Conversion, Renewable Energy Integration, High-Efficiency DC Power Conversion.

1. Introduction:

The modern power distribution system is undergoing a significant transformation with the increasing penetration of Distributed Energy Resources (DERs), including solar photovoltaic (PV) systems, wind turbines, and energy storage units. These resources offer advantages such as renewable energy integration, reduced transmission losses, and enhanced system flexibility. However, their intermittent and decentralized nature introduces several operational challenges, including voltage fluctuations, feeder overloading, increased line losses, and degradation of power quality.

Grid-tied inverters play a crucial role in integrating distributed generation into the power system. These inverters are broadly classified into grid-following and grid-forming types. Grid-forming inverters regulate voltage and frequency in islanded microgrids, whereas grid-following inverters synchronize with the existing grid and inject controlled active and reactive power. Due to their cost-effectiveness, scalability, and ease of implementation, grid-following inverters are widely used in renewable energy systems. However, as their penetration increases, the collective dynamic behavior of multiple inverters significantly impacts microgrid stability.

The interaction between multiple grid-following inverters, each with different ratings, control parameters, and connection impedances, introduces complex dynamic phenomena that are difficult to model using traditional techniques. Microgrids, which integrate distributed generation, storage systems, and controllable loads, have emerged as key components of modern smart grids. These systems can operate in both grid-connected and islanded modes, providing flexibility and resilience.

High penetration of inverter-based resources reduces system inertia, leading to faster frequency deviations and voltage oscillations during disturbances. Therefore, accurate modeling and analysis of inverter-dominated microgrids are essential for system planning and stability assessment. Conventional modeling approaches, such as detailed switching models and

electromagnetic transient simulations, become computationally intensive for large-scale systems. Additionally, simplified models often assume identical inverter characteristics, which do not reflect real-world heterogeneity.

Another important challenge in modern distribution systems is the fair and efficient utilization of DERs. Traditional control strategies focus primarily on maximizing power output or maintaining system constraints, often neglecting fairness among multiple sources. This can result in uneven utilization, where some DERs are heavily curtailed while others operate below capacity. To address this issue, the concept of equitable active-reactive (P-Q) power envelopes has been introduced. These envelopes define operational limits for DERs, ensuring fair participation while maintaining system constraints such as voltage limits and thermal ratings.

The increasing demand for electric vehicles (EVs) further emphasizes the need for efficient power conversion systems. EVs require reliable low-voltage power supplies derived from high-voltage DC buses. Conventional silicon-based converters face challenges such as high losses, thermal issues, and bulky designs. Emerging technologies like Gallium Nitride (GaN) devices offer high switching frequency, reduced losses, and compact size, making them suitable for modern EV applications.

In addition to hardware advancements, intelligent control strategies play a vital role in improving system performance. Techniques such as adaptive control, load sharing, and real-time monitoring enhance efficiency, reliability, and safety. By integrating advanced power electronics with AI-based control, it is possible to develop next-generation energy systems that are efficient, compact, and adaptive.

This research focuses on developing an AI-driven switched-capacitor dual-input converter that integrates solar PV and battery energy storage systems. The proposed approach addresses key challenges in hybrid energy systems, including efficient power sharing, dynamic response, and intelligent energy management, thereby contributing to the advancement of modern renewable energy systems.

2. Literature Review:

In the paper titled “Dynamic Aggregation of Grid-Tied Three-Phase Inverters”, V. C. S. Purba, B. B. Johnson, S. Jafarpour, F. Bullo, and S. V. Dhople present an efficient approach for modeling large-scale inverter-based systems. The authors address the computational complexity of detailed inverter modeling by proposing a dynamic aggregation technique that groups inverters based on electrical proximity and impedance characteristics. Their method involves linearizing inverter dynamics, including current control loops, LCL filters, and phase-locked loop (PLL) behavior, and representing them in a reduced-order state-space form. By applying clustering techniques and network reduction methods such as Kron reduction, the aggregated model retains essential dynamic characteristics while significantly reducing system complexity. The study demonstrates that the proposed model accurately captures system transients and can be effectively used for controller design and disturbance analysis.

In another significant contribution, “Singular Perturbation and Small-Signal Stability for Inverter Networks”, S. Jafarpour, V. Purba, S. Dhople, B. Johnson, and F. Bullo investigate the stability characteristics of inverter-dominated power systems using singular perturbation theory. The authors focus on the separation of system dynamics into slow and fast time scales, where slow dynamics correspond to outer control loops and fast dynamics represent current control and filter behavior. By simplifying the system through elimination of fast states, they derive reduced-order models that enable efficient stability analysis. The study provides explicit mathematical conditions that relate controller gains, filter parameters, and network impedance to system stability. This work offers valuable insights into the design of stable inverter-based systems and highlights the importance of time-scale interactions in power electronic networks.

Similarly, in the article “Reduced-Order Aggregate Model for Parallel-Connected Single-Phase Inverters”, V. Purba, B. B. Johnson, M. Rodriguez, S. Jafarpour, F. Bullo, and S. V. Dhople propose a reduced-order modeling approach specifically for photovoltaic (PV) applications involving multiple parallel-connected inverters. The authors develop a methodology that preserves key dynamic behaviors such as power sharing, current limiting, and anti-islanding protection while reducing computational burden. The aggregation process is based on capacity-weighted scaling of control parameters and equivalent representation of current saturation limits. Additionally, the model incorporates correction factors to account for harmonic and resonance effects associated with LCL filters. Simulation results under varying solar conditions confirm that the aggregated model accurately reproduces system dynamics and provides a reliable tool for large-scale PV system analysis.

3. Methodology:

Existing System and Its Limitations:

The existing energy conversion architectures used in solar photovoltaic (PV) and battery-based energy systems primarily rely on conventional DC-DC converter topologies such as buck, boost, buck-boost, interleaved, and isolated converters. These converters are typically designed for single-input operation, meaning they can process power either from the PV array or from the battery at a given time, but not both simultaneously. As a result, hybrid energy systems require multiple converters one for PV regulation, another for battery charging/discharging, and sometimes an additional power-conditioning stage. This leads to increased system cost, larger size, higher switching losses, and greater overall complexity.

Although switched-capacitor (SC) converters have been introduced to reduce size and improve efficiency, they exhibit several limitations. Conventional SC converters generally lack bidirectional power flow capability and offer limited voltage gain, making them unsuitable for handling wide variations in PV output and dynamic battery conditions. Furthermore, most SC-based topologies are passive and do not provide intelligent coordination between multiple energy sources based on real-time load demand or environmental conditions.

Another critical limitation of existing systems is the absence of artificial intelligence (AI)-based control. Traditional control techniques such as proportional-integral-derivative (PID), voltage-mode, and current-mode control operate using fixed rule-based logic. These methods cannot effectively adapt to variations in solar irradiance, battery state of charge, temperature fluctuations, or sudden load changes. Consequently, the system operates under suboptimal conditions, leading to inefficient power sharing, reduced system lifespan, and increased stress on power electronic components.

In addition, current hybrid PV-battery systems lack advanced energy management strategies such as dynamic optimization, predictive control, and fault-tolerant operation. Most systems rely on simple threshold-based switching between PV

and battery sources, which results in delayed response and inefficient energy utilization. These systems are unable to predict future energy availability or load demand, thereby limiting their overall efficiency, responsiveness, and reliability. Due to these drawbacks including high component count, inefficiency during multi-source operation, lack of intelligent control, restricted voltage conversion capability, and absence of predictive energy coordination there is a strong need for an AI-driven dual-input switched-capacitor converter that can intelligently manage hybrid energy sources, improve efficiency, reduce system size, and enhance power quality.

Disadvantages:

- The existing solar PV-battery energy systems suffer from several limitations that hinder their operational efficiency, flexibility, and adaptability in modern renewable energy applications. One of the primary drawbacks is the use of single-input DC-DC converters, which necessitate separate converters for PV regulation and battery management. This results in increased component count, higher installation cost, larger system size, and additional switching losses due to multiple stages of power conversion.
- Another significant disadvantage is the lack of real-time intelligent control. Conventional systems rely on fixed rule-based controllers such as PID, voltage-mode, and current-mode control, which do not adapt effectively to changing environmental conditions. Variations in solar irradiance, temperature, and load demand can cause these systems to operate inefficiently, reducing power extraction from PV panels and accelerating battery degradation due to improper charge management.
- Existing switched-capacitor converters also face notable challenges. Despite their compact design, traditional SC converters provide limited voltage gain, reduced efficiency under high load conditions, and lack bidirectional power flow capability. Moreover, they are unable to simultaneously manage multiple energy inputs, restricting their applicability in hybrid renewable systems.
- Furthermore, current systems lack a unified energy management framework capable of coordinating PV and battery sources simultaneously. Most implementations use threshold-based switching logic, which leads to delayed responses, inefficient decision-making, and poor energy utilization. This can cause frequent switching between sources, resulting in instability, increased switching stress, and reduced converter lifespan.
- Another limitation is the absence of advanced fault detection and fault-tolerant mechanisms. Existing systems are unable to detect abnormalities such as PV voltage fluctuations, battery overcurrent conditions, or capacitor stress in real time. This lack of predictive fault monitoring reduces system reliability and increases maintenance requirements.
- Overall, existing energy conversion architectures are characterized by high complexity, limited efficiency, lack of adaptability, restricted voltage operation, and absence of intelligent coordination. These limitations highlight the necessity for an AI-driven dual-input switched-capacitor converter capable of improving reliability, adaptability, and overall energy management in hybrid renewable energy systems.

Architecture Diagram:

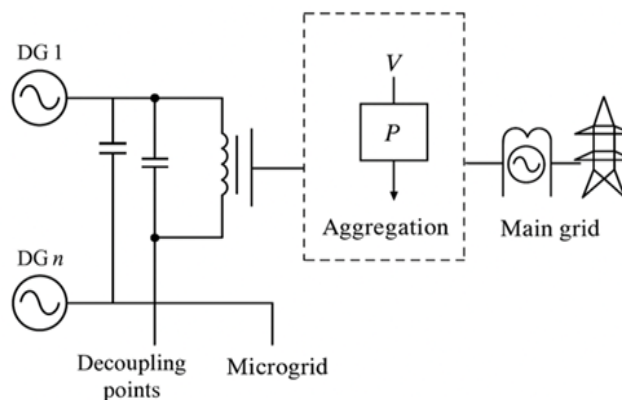

The existing system consists of multiple Distributed Generation (DG) units, primarily solar photovoltaic (PV) panels and wind turbine generators. These renewable sources generate DC power and variable-frequency AC power, respectively, depending on environmental conditions. The solar PV system typically has a rated power of 5 kW per module, with an operating voltage range of 300-600 V DC, and incorporates Maximum Power Point Tracking (MPPT) control to maximize energy extraction. The wind turbine system has a rated power of 3 kW and produces variable-frequency AC output, which is rectified to DC before further processing. The turbine operates within a speed range of 100-800 rpm.

All renewable sources are interfaced with the microgrid through power electronic converters to regulate voltage and control power flow. The DC outputs from these sources are connected to a common DC-link, which acts as an intermediate stage before inversion to AC. A DC-link capacitor, typically ranging from 1000 μ F to 5000 μ F, is used to stabilize the voltage and act as an energy buffer during transient conditions.

An Energy Storage System (ESS), such as a lithium-ion battery or supercapacitor, is connected to the DC bus through a bidirectional DC-DC converter. The battery is typically rated at 48 V, 100 Ah, and the converter operates in both buck and boost modes. The control strategy is based on the State of Charge (SOC) to manage charging and discharging cycles effectively. The ESS plays a crucial role in compensating for renewable power fluctuations and ensuring continuous and stable power delivery.

Each DG unit is connected to the AC microgrid using grid-following inverters. These inverters synchronize with the grid using Phase-Locked Loop (PLL) techniques and operate under active and reactive power (P-Q) control or droop control strategies to enable proportional load sharing. The inverters are typically rated at 5 kVA, operate at switching frequencies between 10-20

kHz, and use a double-loop control structure consisting of an outer voltage loop and an inner current loop. Sinusoidal Pulse Width Modulation (PWM) is employed for switching control.

The system supplies a variety of loads, including resistive, inductive, and non-linear loads, to simulate real-world operating conditions. The total load demand ranges from 10 to 15 kW and includes residential loads such as lighting and fans, industrial loads such as motors and heaters, and non-linear loads such as rectifier-based drives. These varying load conditions introduce voltage and frequency fluctuations, posing challenges for stable system operation.

All inverter outputs are connected at the Point of Common Coupling (PCC), which serves as the interface between the microgrid and the main utility grid. The PCC operates at a nominal voltage of 415 V (three-phase) and a frequency of 50 Hz. It is connected through circuit breakers and LCL filters to ensure smooth power exchange and reduce harmonics.

The control and communication layer of the existing system is primarily decentralized, where each inverter operates independently based on local measurements. Controllers such as Proportional-Integral (PI) regulators are used for voltage and current control, while droop control manages power sharing. PLL is used for synchronization with the grid. However, limited communication between units leads to inaccuracies in power sharing and poor dynamic response during transient conditions.

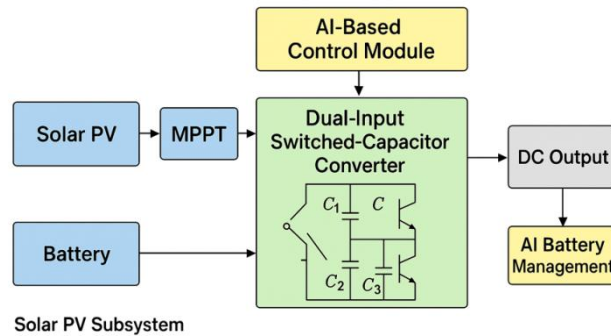

Proposed System:

The proposed system introduces an AI-driven dual-input switched-capacitor (SC) DC-DC converter designed to integrate solar PV and battery energy storage within a unified and intelligent power conversion architecture. Unlike conventional systems that rely on multiple converters and fixed control strategies, the proposed system combines an advanced converter topology with machine learning-based control to achieve efficient, adaptive, and predictive energy management.

At the hardware level, the system employs a switched-capacitor dual-input converter that allows simultaneous or independent operation of both PV and battery sources. The converter supports bidirectional power flow, enabling efficient battery charging and discharging based on system requirements. The SC topology reduces the need for bulky inductors, minimizes conduction losses, lowers electromagnetic interference, and provides multiple voltage conversion ratios. This results in a compact, efficient, and reliable system compared to traditional multi-stage converters.

The key innovation of the proposed system lies in its AI-driven control algorithm. Advanced machine learning techniques, such as reinforcement learning and neural network-based predictive models, are used to dynamically manage power flow between the PV system and battery storage. The controller continuously analyzes real-time parameters such as solar irradiance, battery state of charge (SOC), temperature, load demand, and historical energy patterns. Based on this data, it optimally allocates power, ensuring maximum energy extraction from the PV system and efficient battery utilization.

In addition to energy optimization, the system incorporates intelligent fault detection mechanisms. AI models monitor voltage, current, and temperature signals to identify potential issues such as capacitor stress, PV shading effects, and battery over current conditions. This predictive capability enables early fault detection, reduces maintenance costs, and enhances overall system reliability.

The proposed system also features advanced energy management functions, including automatic mode selection (MPPT mode, battery charging mode, and hybrid supply mode), source prioritization, and real-time switching optimization. These features ensure smooth transitions between energy sources, reduce switching stress, and maintain stable output voltage under varying operating conditions.

Overall, the AI-driven dual-input switched-capacitor converter offers significant improvements over existing systems in terms of efficiency, adaptability, reliability, and intelligent control. It provides a scalable and robust solution for modern hybrid renewable energy systems, supporting applications such as DC microgrids, solar home systems, EV charging stations, and distributed energy storage networks.

4. System Implementation:

The Arduino Integrated Development Environment (IDE) is a user-friendly software platform that serves as the primary interface for programming Arduino microcontroller boards. It provides a comprehensive set of tools and features for developing embedded systems and interactive electronic applications. The IDE is designed to be accessible to both beginners and experienced programmers, making it widely used in academic, research, and industrial environments.

One of the key features of the Arduino IDE is its simplicity and ease of use. It utilizes a simplified version of the C and C++ programming languages, allowing users with varying levels of programming expertise to develop applications efficiently. The IDE offers an intuitive environment for writing, editing, and managing code, with built-in features such as syntax highlighting, auto-completion, and error detection that enhance the coding experience. Additionally, it provides a rich collection of pre-written libraries and example programs, enabling users to implement complex functionalities with minimal effort.

Another important advantage of the Arduino IDE is its compatibility with a wide range of Arduino microcontroller boards. These boards are available in various configurations with different processing capabilities, memory sizes, and input/output

options. The IDE allows users to easily select and configure the appropriate board and communication port, ensuring flexibility in hardware selection for different applications such as sensor interfacing, automation, robotics, and IoT systems.

The Arduino IDE also simplifies the process of code compilation and uploading. With a single click, users can compile their programs and upload them to the microcontroller via a USB connection. This streamlined workflow enables rapid prototyping, testing, and debugging. Furthermore, the built-in serial monitor provides a real-time communication interface between the microcontroller and the computer, which is useful for data visualization, debugging, and system monitoring.

In addition to its technical features, the Arduino IDE benefits from a strong and active open-source community. This community contributes a vast collection of libraries, modules, and shields that extend the functionality of Arduino-based systems. Extensive documentation, tutorials, and online forums are available to support users in troubleshooting and project development.

In conclusion, the Arduino IDE is a powerful and versatile development platform that enables the creation of a wide range of embedded and electronic systems. Its intuitive interface, hardware compatibility, and strong community support make it an essential tool for education, prototyping, and advanced system design.

Simulation Diagram:

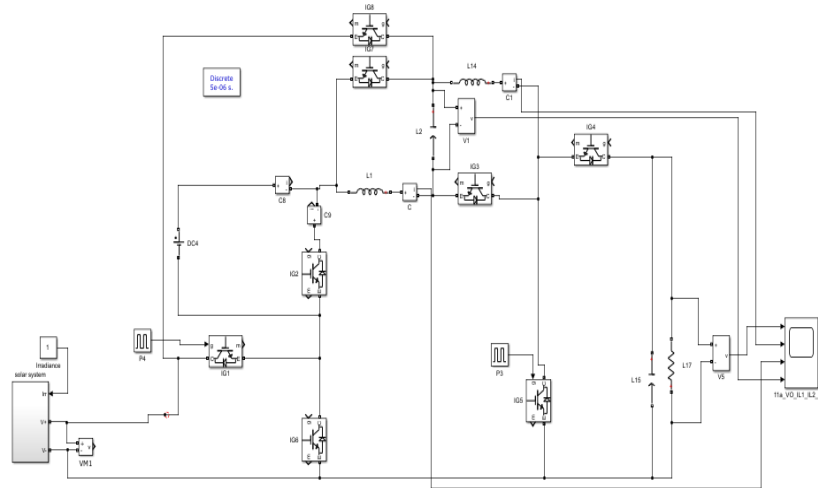

Simulation Output:

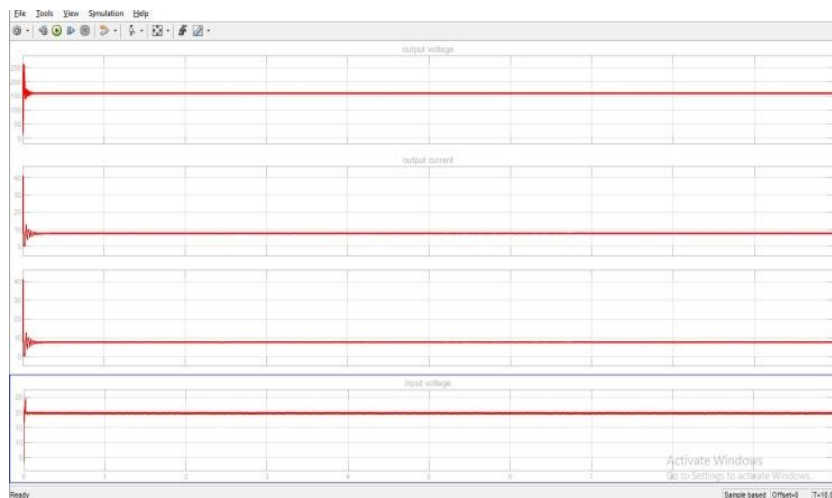

5. Results and Discussion:

The diagram represents a solar-based power conversion and control system developed using power electronic components, switching devices, measurement blocks, and filtering elements, typically modeled in a MATLAB/Simulink environment. The system begins on the left side with a solar photovoltaic (PV) source, which is connected to an irradiance and voltage measurement subsystem to monitor environmental and electrical parameters. A voltage measurement block (VM1) is used to continuously track the PV output voltage for analysis and control purposes.

The output from the PV source is passed through the first power electronic switch (IG1), which is controlled by a gating pulse generator labeled P4. This switching stage regulates the initial flow of power from the PV module into the system. The output is then fed into a DC-link stage consisting of a capacitor (DC4) and inductive components, which act as an energy buffer and help stabilize voltage during transient conditions. A controlled IGBT pair (IG2), along with passive components such as capacitors (C8, C9) and an inductor (L1), further regulates the intermediate DC power and smooths fluctuations.

At the top central portion of the system, two IGBTs (IG7 and IG8) form part of a boost converter or bidirectional DC-DC conversion stage. This section is supported by inductors (L2, L14) and a capacitor (C1), which collectively function to increase and stabilize the DC bus voltage. This stage plays a crucial role in maintaining a consistent voltage level required for downstream conversion processes.

Moving towards the center-right, another switching stage (IG3) is connected through additional capacitive and inductive filtering networks. This stage further conditions the DC power before it is supplied to the inverter section. On the far right side, switching devices (IG4 and IG5), along with inductors (L15, L17) and a voltage measurement block (V5), form the DC-AC

inverter stage. This inverter converts the regulated DC power into AC power suitable for supplying loads or interfacing with the grid. The inverter switches are controlled using a PWM pulse generator (P3), which ensures proper switching sequences and output waveform quality.

All outputs from different stages converge to a centralized measurement block labeled (11a_VO_I, L1_L2_VC). This block captures critical system parameters such as output voltage, inductor currents, and capacitor voltages, providing a comprehensive monitoring interface for performance evaluation and control.

Overall, the system represents a multi-stage power conversion architecture consisting of a PV source, DC-DC converter stages, energy conditioning elements (inductors and capacitors), a DC-AC inverter, and integrated measurement and control units. This model reflects a detailed and practical implementation of a solar PV-based power electronics system, commonly used for simulation and analysis in MATLAB/Simulink environments.

6. Hardware Implementation:

Hardware Block Diagram:

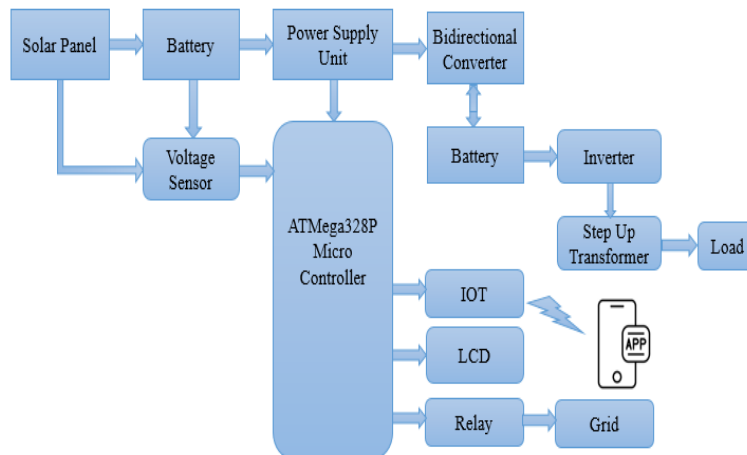

Proposed System Hardware Description and Working:

The proposed AI-driven switched-capacitor dual-input converter for solar PV and battery energy systems consists of a solar photovoltaic source, battery storage unit, switched-capacitor converter circuit, intelligent controller, sensing unit, and load interface. The hardware architecture is designed to enhance power conversion efficiency, reduce system size, and enable intelligent energy management under varying operating conditions.

- **Solar Photovoltaic Source:** The solar photovoltaic (PV) panel serves as the primary renewable energy source in the system. It converts solar irradiance into direct current (DC) electrical energy and supplies power to the dual-input converter. Depending on system requirements, PV modules with ratings such as 12 V or 24 V can be employed. The PV output varies with environmental conditions such as irradiance and temperature, making efficient power extraction essential.
- **Battery Energy Storage System:** A rechargeable battery is used as the secondary energy source. It stores excess energy generated by the PV system and supplies power during low solar irradiance or nighttime conditions. Common battery types include lithium-ion and lead-acid batteries. The battery ensures continuity of power supply and improves system reliability by compensating for fluctuations in renewable energy generation.
- **Switched-Capacitor Dual-Input Converter:** The switched-capacitor (SC) dual-input converter forms the core of the power conversion stage. It enables simultaneous or independent processing of energy from both the PV source and the battery. Unlike conventional converters, it utilizes capacitors and semiconductor switches instead of bulky inductors, resulting in a compact and lightweight design. The converter performs voltage boosting and regulates power flow efficiently between the sources and the load.
- **Power Semiconductor Switches:** MOSFET switches are employed for high-frequency switching operations within the converter. These switches are controlled using Pulse Width Modulation (PWM) signals generated by the controller. High-speed switching improves efficiency, reduces conduction and switching losses, and enables precise control of power flow.
- **Capacitor Network:** The SC topology incorporates a network of capacitors that undergo periodic charging and discharging cycles. This capacitor network facilitates energy transfer, provides voltage conversion, and contributes to reduced system size and improved efficiency. Proper capacitor selection is crucial to minimize ripple and enhance system performance.
- **AI-Based Controller:** An intelligent controller such as Arduino, ESP32, STM32, or Raspberry Pi is used to control the converter operation. The AI-based algorithm continuously monitors system parameters and dynamically optimizes power flow between the PV source, battery, and load. It enables adaptive control based on real-time conditions such as solar irradiance, battery state of charge (SOC), temperature, and load demand. The controller also ensures battery protection and maximizes energy utilization.
- **Sensor Unit:** The system incorporates voltage, current, and temperature sensors to monitor real-time operating conditions. These sensors provide feedback to the AI controller, enabling intelligent decision-making, system optimization, and protection against abnormal conditions.

- Gate Driver Circuit: A gate driver circuit is used to provide appropriate gate signals to the MOSFET switches. Driver ICs such as IR2110 ensure reliable switching performance, proper signal amplification, and electrical isolation between control and power circuits.
- Load Interface: The output of the converter is connected to DC loads or inverter-fed AC loads. The system is capable of supplying power to applications such as LED lighting, DC motors, household appliances, and other renewable energy-based systems.

Working Operation:

Initially, the solar PV panel generates DC power from sunlight and supplies it to the dual-input switched-capacitor converter. The converter simultaneously receives energy from the battery storage system when required. Based on real-time feedback from sensors, the AI-based controller regulates the switching pulses of the MOSFETs to maintain a stable output voltage and efficient power flow.

During periods of high solar irradiance, excess energy generated by the PV panel is used to charge the battery while also supplying the load. Conversely, during low irradiance conditions or increased load demand, the battery provides additional power to support the system. The intelligent controller ensures smooth coordination between the PV source and battery, minimizes energy losses, and maintains continuous power supply. Thus, the proposed system achieves efficient, reliable, and adaptive energy management for hybrid renewable energy applications.

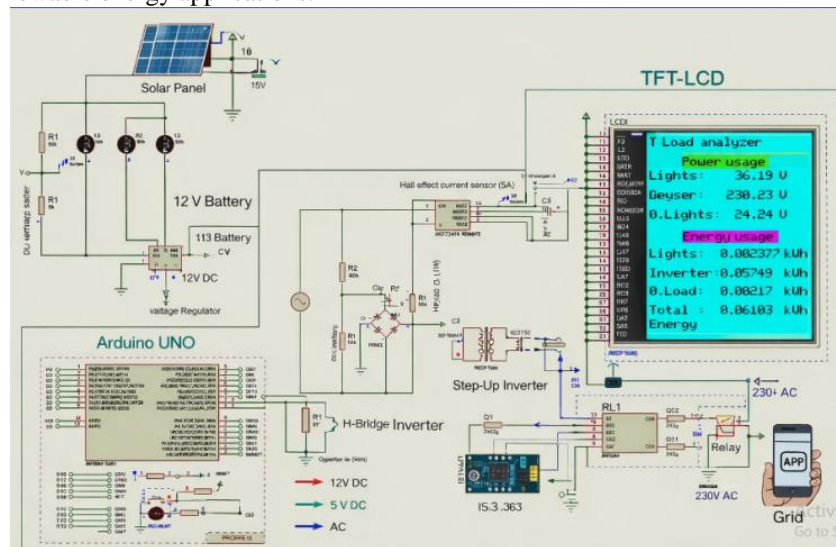

7. Conclusion:

The simulation circuit successfully demonstrates an integrated solar energy conversion system capable of managing both active and reactive power through multiple power electronic stages. By incorporating DC-DC converters, filtering components, PWM-controlled switching devices, and an inverter stage, the system ensures efficient extraction of energy from the solar PV source and stable delivery of conditioned power to the load.

The inclusion of measurement blocks throughout the circuit enables continuous monitoring of key parameters such as voltage, current, and capacitor dynamics. This ensures that the system operates within safe limits while maintaining high power quality. Each stage of the conversion process performs a specific function, including voltage boosting, DC-link stabilization, switching control, and AC power generation, contributing to overall system efficiency and reliability.

The results validate the effectiveness of coordinated control in distributed energy resource (DER)-based systems, where multiple conversion stages work together to achieve optimal performance. The system aligns with modern grid requirements by providing flexibility, dynamic response, and operational stability under varying conditions. Overall, the simulation confirms that the proposed architecture is technically feasible and robust, offering a strong foundation for further optimization, hardware implementation, and real-time control in advanced renewable energy applications.

8. Future Scope:

The proposed AI-driven switched-capacitor dual-input converter presents several opportunities for future research and development. Advanced machine learning and deep learning techniques can be explored to enhance adaptive control, improve fault prediction accuracy, and enable real-time optimization under rapidly changing solar irradiance and load conditions.

The system can be extended to support multiple renewable energy sources, such as wind energy and super capacitors, transforming it into a multi-port energy management system suitable for microgrid applications. Future work may also focus on hardware implementation using advanced embedded platforms such as Digital Signal Processors (DSPs), Field-Programmable Gate Arrays (FPGAs), or edge-AI controllers to validate real-time performance and scalability.

Further improvements in efficiency and power density can be achieved by incorporating wide-bandgap semiconductor devices such as Silicon Carbide (SiC) and Gallium Nitride (GaN), along with optimized switched-capacitor converter topologies. In addition, integrating battery state-of-health estimation and predictive battery management techniques can significantly enhance battery lifespan and overall system reliability.

The proposed converter can also be adapted for emerging applications such as electric vehicle charging systems, smart grids, and off-grid renewable energy storage solutions. Future research may address critical aspects such as cyber security, fault-tolerant control, and seamless grid integration to ensure safe, reliable, and efficient deployment in real-world renewable energy infrastructures.

References:

1. De Souza, A. F., Tofoli, F. L., & Ribeiro, E. R. (2021). Switched capacitor DC-DC converters: A survey on the main topologies, design characteristics, and applications. *Energies*, 14(8), 2231.
2. Khawarizmi, A., & Lee, L. (2022). Design of a high-efficiency switched-capacitor (SC) DC-DC converter. *F1000Research*, 11, 541.
3. Sepahvandi, A., Rezaeealam, B., & Mikhak-Beyranvand, M. (2024). A single-switch high step-up DC-DC converter derived from coupled inductor and switched capacitor for a photovoltaic system. *Scientific Reports*.
4. Shaabani, M., Mirzaei, A., Rezvanyvardom, M., Khosravi, F., & Gorji, S. A. (2023). A hybrid switched-inductor/switched-capacitor DC-DC converter with high voltage gain using a single switch for photovoltaic application. *Energies*.
5. Ertekin, D. (2024). A high-gain switched-inductor-capacitor DC-DC boost converter for photovoltaic-based microgrid applications. *CSEE Journal of Power and Energy Systems*.
6. Kurdkandi, N. V., Khosroshahi, A. E., & Hosseini, S. H. (n.d.). A switched-capacitor DC-DC converter with voltage regulation for photovoltaic applications.
7. Pellitteri, F., Di Dio, V., Puccio, C., & Miceli, R. (2022). A model of DC-DC converter with switched-capacitor structure for electric vehicle applications. *Energies*, 15(3), 1224.
8. Das, K., et al. (2023). Electric vehicle battery capacity degradation and health estimation using machine-learning techniques: A review. *Clean Energy*.
9. Li, K., & Chen, X. (2025). Machine learning-based lithium battery state-of-health prediction research. *Applied Sciences*, 15(2), 516.
10. Jo, S., Jung, S., & Roh, T. (n.d.). Battery state-of-health estimation using machine learning and preprocessing with relative state-of-charge.
11. Jiang, S., Shi, J., & Moura, S. (2024). Relax, estimate, and track: A simple battery state-of-charge and state-of-health estimation method. *arXiv preprint*.
12. Kulkarni, A., & Teodorescu, R. (2024). Computationally efficient machine-learning-based online battery state-of-health estimation. *arXiv preprint*.
13. Cai, N., Qin, Y., Chen, X., & Wu, K. (2022). DIICAN: Dual time-scale state-coupled co-estimation of SOC, SOH, and RUL for lithium-ion batteries. *arXiv preprint*.